

Near-infrared wavelengths may be used for separating images into surface texture and pure color information.



VideometerLab

Multispectral vision for quality inspection

VideometerLab is a vision-based system for color and texture measurements - or in more general terms: visual quality. VideometerLab integrates illumination, camera, and computer technology with advanced digital image analysis and statistics. It is an easy-to-use system for accurate quantitative measurements of visual properties of samples or surfaces.

Employing light emitting diode (LED) technology, the VideometerLab can be optimized for a given application and is not restricted to the wavelengths spanned by traditional RGB technology. VideometerLab is accurately calibrated to provide high-resolution multispectral images.

VideometerLab features the following advantages compared to standard color imaging:

- The response of the sample in up to 10 spectral bands may be determined in every pixel of the high-resolution image.
- Accurate spectral and spatial calibrations ensuring high reproducibility of the acquired images.
- Near-infrared (NIR) information can be obtained, producing images mainly sensitive to surface structures and composition, rather than the color information, of the sample.
- Ultraviolet (UV) reflectance and fluorescence information can be obtained.
- A more accurate and flexible color measurement, compared to standard RGB technology, is obtained.
- Individual adjustment of the light intensity for each wavelength band, resulting in an improved signal-to-noise ratio.
- Automatic change of dynamic range, depending on the application.
- Increased lifetime of the light sources (in the 100,000 hour range), i.e. the need for maintenance is practically eliminated.
- Increased stability due to less heating from LEDs compared to traditional light sources.
- Robust image acquisition and feature extraction improving the quality of the image, as well as reducing the sensitivity to random variations in the measured object.

Near-infrared light penetrates deeper into the surface of the object. In combination with powerful data analysis tools this may reveal structures that are usually not visible.

Videometer





Customized with a selected combination of LEDs the VideometerLab is a valuable tool for quality control based on visual inspection.

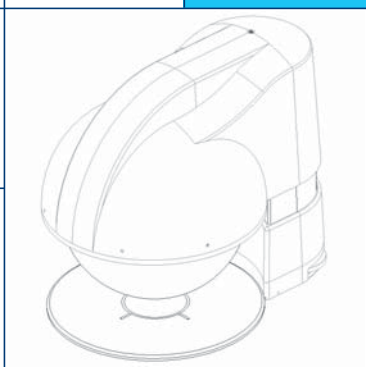
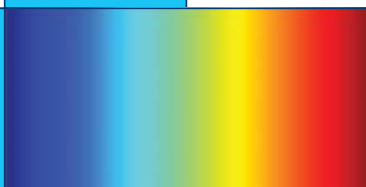

VideometerLab

Technical Specifications

Light sources	Light emitting diodes (LED).
Spectral resolution	The standard configuration features ten bands: 428, 472, 503, 515, 592, 612, 630, 700, 875 (NIR), and 940 (NIR) nm. The equipment may be customized for a given application to contain from 1 to 10 selected wavelengths in the range from 370 to 1000 nm.
Spatial resolution	1380×1035 pixels (standard configuration). May be customized according to the application.
Optics	Schneider XNP 1.4/17 C-mount lens field of view: circular, diameter 100 mm pixel size: 0.12×0.12 mm Schneider XNP 1.4/23 C-mount lens field of view: partially circular, 93×100 mm pixel size: 0.09×0.09 mm Schneider XNP 1.4/35 C-mount lens field of view: 53×70 mm pixel size: 0.05×0.05 mm May be customized according to the required spatial resolution and quality using other C-mount lenses.
Sample size	Max. diameter 100 mm. Max. height 100 mm.
Dynamic range	Adjustable according to the application.
Time of analysis	10 seconds (corresponding to an accumulation of 10 scans using 10 wavelengths).
Dimensions	580 mm (h) × 420 mm (w) × 600 mm (d)
Weight	27 kg
Power supply	85-264 VAC, 47-63 Hz
Power consumption	Max. 200 VA
Ambient temperature	0-40 °C
Ambient humidity	20-80 % relative humidity (non-condensing)
PC requirements	Intel Pentium 4 processor with 512 MB RAM (minimum).
Software	Windows 2000 operating system. VideometerLab control software including image acquisition, image processing, and image statistics tools.
Software interface	Microsoft® Excel. Images can be exported to standard image formats (TIFF, BMP).
Software options	Videometer Toolbox for Matlab® Pattern Recognition Toolbox ImagePro® Plus

Videometer A/S develops vision systems for automated visual inspection. Both laboratory and in-line systems including dedicated software is developed.



Videometer A/S
Lyngsø Allé 3
DK-2970 Hørsholm
Denmark
Tel. +45 45761077
Fax +45 45761041
Email: mail@videometer.com
www.videometer.com